



EAGLE FLIGHT[®] STAINLESS STEEL WHEEL SIMULATORS

Type Q INSTALLATION INSTRUCTIONS

19.5" Ring Mount Universal Wheel Simulators

Front Axle Set

- 2 Front Wheel Simulators
- 2 Mounting Rings
- 8 Attachment Screws
- 2 Pop Out Centers
- 2 Center Emblems
- 1 Installation Tool

Rear Axle Set

- 2 Rear Wheel Simulators
- 2 Mounting Rings
- 8 Attachment Screws
- 2 Pop Out Centers
- 2 Center Emblems
- 1 Installation Tool
- 4 Air Inflation Hoses

Note: This system can be installed with the installation tool provided. No other tools are necessary. Do not use power tools for installation. Eagle Flight[®] recommends storing the tool with the vehicle's tire tool for future use.

Installation Instructions

1. Remove foreign material that may be stuck inside the curled outer lip of the steel wheel so that the mounting ring can seat properly.
2. Place the attachment ring into the curled outer lip of the wheel with the rubber screw retainers facing outward. If there is a wheel weight, place the u-bend in the ring over it.
3. Expand the ring by tightening the nut. Expand the ring until it is held firmly in its seat.
4. For Rear Wheels Install the air inflation hoses to the rear wheels. The 15" hoses are for the outside wheels and the 24" hoses are for the inside wheels.
5. For Rear Wheels place the hoses in the two holes between the lug nut covers and secure them to the wheel cover with jam nuts. Secure the wheel cover to the attachment ring by using anti-theft screws.
6. Install emblems.
7. Complete steps 1-6 for each wheel.

Typical Front

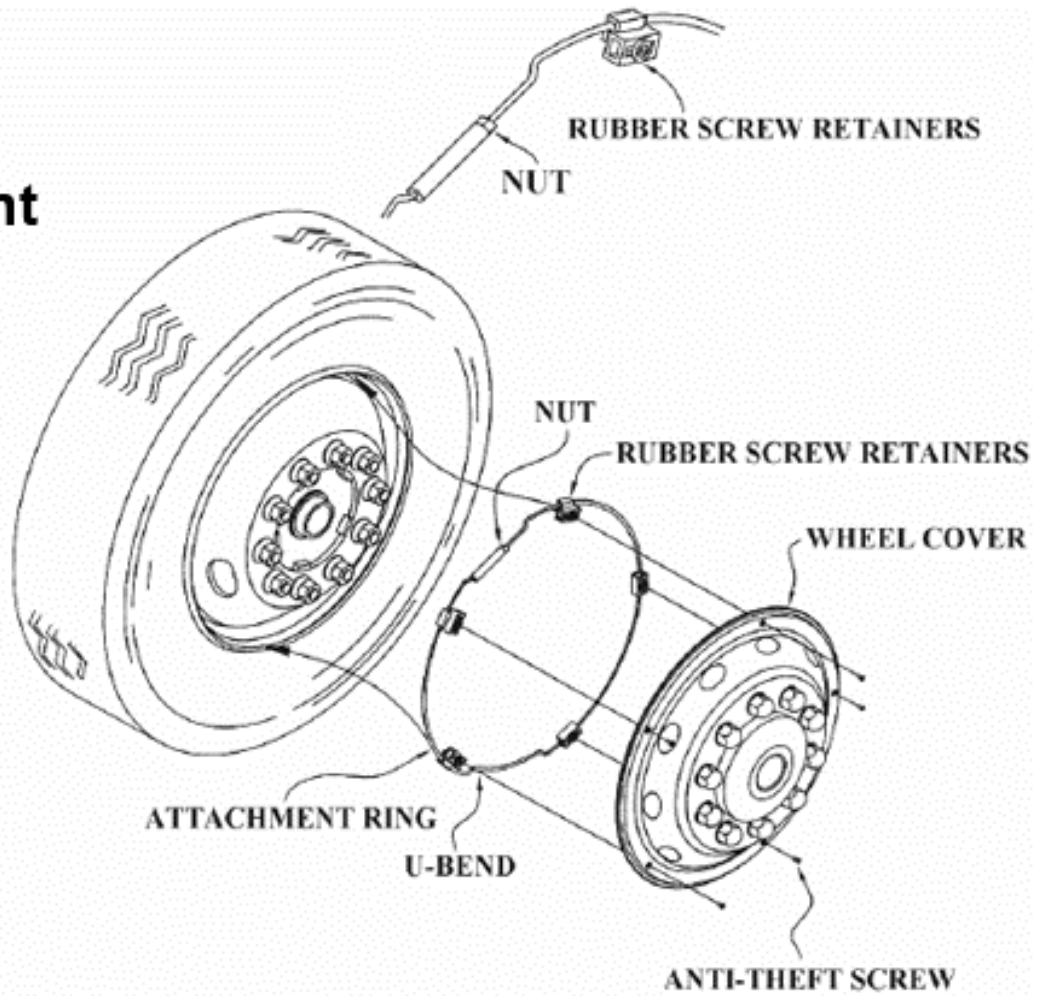

Typical Rear

